

# LIFESMOKE MK9



The Pains Wessex Lifesmoke MK9 is a compact, daylight distress signal designed to be easy and safe to handle. It provides effective position marking during rescue operations and can be used to indicate wind direction, producing dense orange smoke for a minimum of 3 minutes.

## APPLICATION

The Pains Wessex Lifesmoke MK9 is a small and compact distress signal for daylight use designed for stowage in liferafts and lifeboats. SOLAS requires 2 smoke signals per raft/boat.

- Signal for position marking during rescue operations
- Indicates wind direction
- Safe use on oil or petrol covered water
- Conforming to SOLAS 74/88 as amended
- Ideal also for leisure boats

## STORAGE

This compact unit is ideally stored in a water-resistant locker at ambient temperature allowing easy access in an emergency or in the robust, specially designed polybottle.

## OPERATION

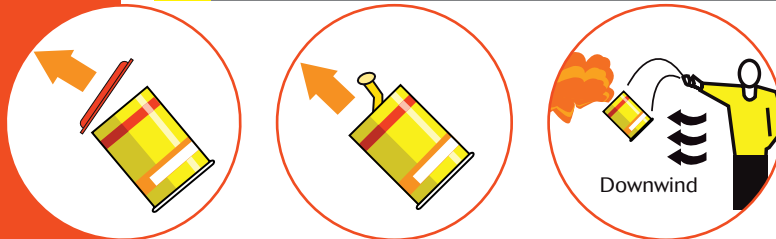

1. Remove plastic cap. Point away from body.
2. Pull tab firmly away from canister. Ensure hand remains clear of HOT END.
3. Throw Lifesmoke overboard immediately. Smoke will be emitted after a 2 second delay.

### WARNING:

- Produces dense orange smoke – do not inhale
- Do not fire in a confined space
- Keep out of reach of children
- Only for emergency use at sea
- If damaged or dented do not use
- Do not dismantle
- Keep away from source of heat
- Do not use after expiry date



### DISPOSAL:

- Pyrotechnics must be treated as hazardous items and must be disposed of responsibly in accordance with local regulations. For help and advice, visit our website [www.painswessex.com](http://www.painswessex.com)

ITEM No.

9537000



Safety of life at Sea (SOLAS)



Marine Equipment Directive (MED)

# LIFESMOKE MK9

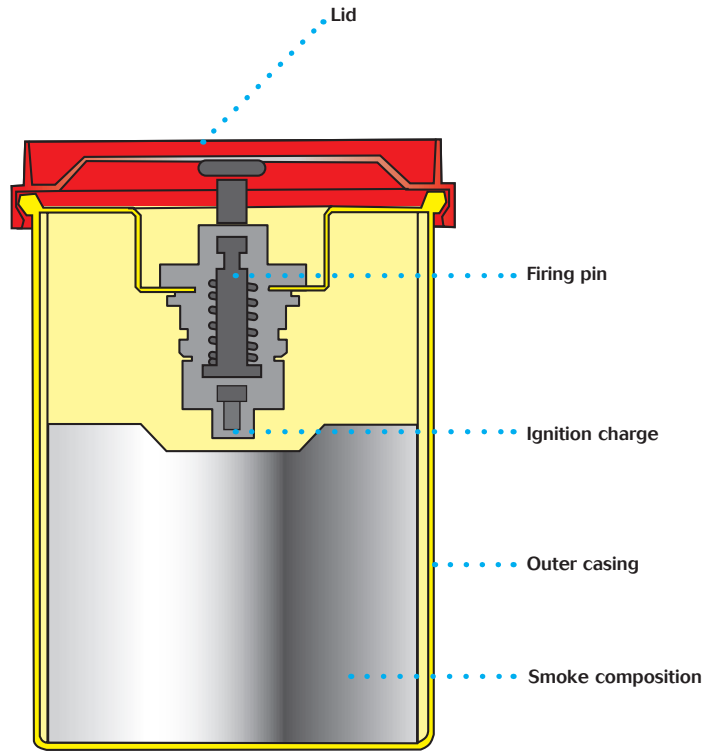

techspec

## ✓ SPECIFICATIONS:

- Height: 114 mm (4.5 ins)
- Diameter: 82 mm (3.2 ins)
- Gross Weight Max. 370g (13.05 oz)
- NEC Max. 239g (8.43 oz)
- Burning time: 3 minutes minimum
- Colour of smoke: orange
- Ignition: percussion ignitor with 2 seconds safety delay

## ✓ APPROVALS

Conforms to SOLAS 74/88 and amendments, Res. MSC 81 (70).  
Approvals: CE 0589, BAM-P1-0191, 0589-P1-0324, BGV MED 423.008,  
USCG 160.122./21/0, 160.022/21/0, TC 006.032.044

## ✓ PACKING & TRANSPORT INFORMATION

- 24 signals in 1 fibreboard box
- Gross weight 9.6 Kgs (21.2 lbs)
- Net weight 8.88 kg (19.58lb)
- Measurements of fibreboard box: 37 x 27 x 26 cms (15 x 11 x 10 ins)
- Net Explosive Content per box: 5.74kg (12.66 lb)
- Hazard Class 1.4S
- UN 0507
- Proper Shipping Name: Signals, Smoke
- Other Information: Passenger and Cargo Aircraft

Authorised Dealer

Drew Marine Signal & Safety UK Ltd  
Langstone Technology Park  
Langstone Road  
Havant  
Hampshire  
PO9 1SA  
United Kingdom

Tel: +44 (0)2392 415700  
Fax: +44 (0)2392 415701  
Email: [info@signalandsafety.com](mailto:info@signalandsafety.com)



Drew Marine Signal & Safety



[www.painswessex.com](http://www.painswessex.com)

Issue:2 06/13